

Enhancing IoT Security Automation for Traceability and Transparency in Dairy Products Supply Chain Using Proof of Work Consensus Protocol from Regional Milk Societies

¹Dr.A.Jameer Basha, ²Margreat Pavithra P, ³Nithya Dharshini, ⁴Nithya Shree

¹Professor and Head, Department of Computer Science and Engineering,
Hindusthan Institute of Technology, Coimbatore

^{2,3,4} UG Students, Department of Computer Science and Engineering,
Hindusthan Institute of Technology, Coimbatore

¹jameer@hit.edu.in, ²720821103065@hit.edu.in, ³720821103077@hit.edu.in,
⁴720821103078@hit.edu.in

ABSTRACT: The food business has typically trailed behind other industries in embracing new technology, and plant automation is no exception. However, fast improvements in computer technology, as well as increased customer and regulatory agency demands for enhanced food quality and safety, have prompted the food sector to contemplate automation of most industrial operations. Though the food business presents numerous specific hurdles to complete automation, the industry has been successful in implementing several automatic operations. Electronic sensors, Arduino, computer vision, expert systems, computer integrated manufacturing, flexible manufacturing systems, systems engineering, and other new technological tools have made it possible to integrate many batch operations into an overall manufacturing system design, allowing for on-line and continuous control capability. In this study, we conducted a literature survey and analysed data from automation in food processing for a variety of applications utilizing Arduino, electronic sensors, and other modules. Then we discovered an Arduino based system that works as a Fruit Sorter machine, an Automatic Bottle Filling Machine, a Bean Cooker, a Food Waste Management System, and A Food Cooking Machine, sorting and grading agricultural products, controlling and monitoring atmospheric conditions or the quality of fruits and vegetables during storage, and so on. This work has improved quality control throughout the manufacturing process. Keep your employees safe, and boost your end- to-end traceability to unrivalled heights. Increase productivity and output rates, safeguard your brand from potentially negative product recalls, increase adaptability and flexibility, and improve supply and demand management to reduce waste

Keywords: Internet of Things (IoT), remote monitoring, Proof of work consensus Protocol, Supply Chain Management, water conservation, Milk Societies.



Corresponding Author: Dr. A.Jameer Basha
Professor & Head / CSE, Hindusthan Institute of Technology
Coimbatore, Tamil Nadu, India
Mail: jameer@hit.edu.in

INTRODUCTION:

Looking at history of food, the world we know today has progressed through hunter-gatherer, agricultural, and industrial stages to become a supplier of goods and services. It is somehow astonishing how far the food manufactures and supply chains have come throughout the years. The discipline devoted to the subject of food is food science and it consists of analytical chemistry, biotechnology, engineering, nutrition, quality control, and food safety management. The food safety system includes food production, processing, packing, distribution/transportation, storage and preparation. Every stage of the food chain should be carried out and monitored scrupulously to enhance food safety. Therefore, Food Safety Management System (FSMS) can be defined as a network of interrelated elements (programs, plans, policies, procedures, practices, processes, goals, objectives, methods, controls, roles, responsibilities, relationships, documents, records, and resources) that combine to avoid potentially dangerous health hazards

Every industry has its own list of unique logistics challenges and issues can arrive from a multitude of sources product type, mode, receiver, market conditions, etc. Working exclusively within the food, beverage, and consumer product sectors, the transportation professionals at Zip line Logistics know the ins-and-outs of these unique challenges. But what are some common food transportation issues most face. Here are we saw the food transportation issues and try to help by using our project.

Our project aims to solve the problem in transportation of food and beverages due to environmental changes in location while transporting the raw material. Many consumer goods are subject to perishability or freeze ability and require temperature controlled transportation. Demand for this equipment has increased dramatically with the consumer preference for fresh and less processed products while the supply has seen little improvement due to the higher cost of ownership and a more challenging regulatory environment. This means significantly tighter capacity and often higher prices when compared to traditional truckload or dry van.



LITERATURE SURVEY

Research on smart temperature control systems in poultry farming has gained significant attention due to the impact of climate conditions on poultry health and productivity. Poultry

birds are highly sensitive to temperature fluctuations, and excessive heat stress can lead to decreased growth rates, reduced egg production, and increased mortality rates. Several studies highlight that maintaining an optimal thermal environment in poultry farms enhances productivity and welfare while reducing economic losses. One of the earliest approaches to temperature control in poultry farms involved manual monitoring and intervention. Farmworkers would use rudimentary tools such as fans, wet curtains, and manual water spraying to control the temperature. However, these methods are labor-intensive, inefficient, and often fail to provide consistent cooling. With advancements in technology; automated climate control systems have been developed. Traditional automated systems rely on thermostats to regulate heating and cooling. However, these systems often lack real-time adaptability and require constant human monitoring. More recent studies have explored the integration of Internet of Things (IoT) and Artificial Intelligence (AI) in poultry farming to develop smart, autonomous temperature control systems.

PROPOSED SYSTEM

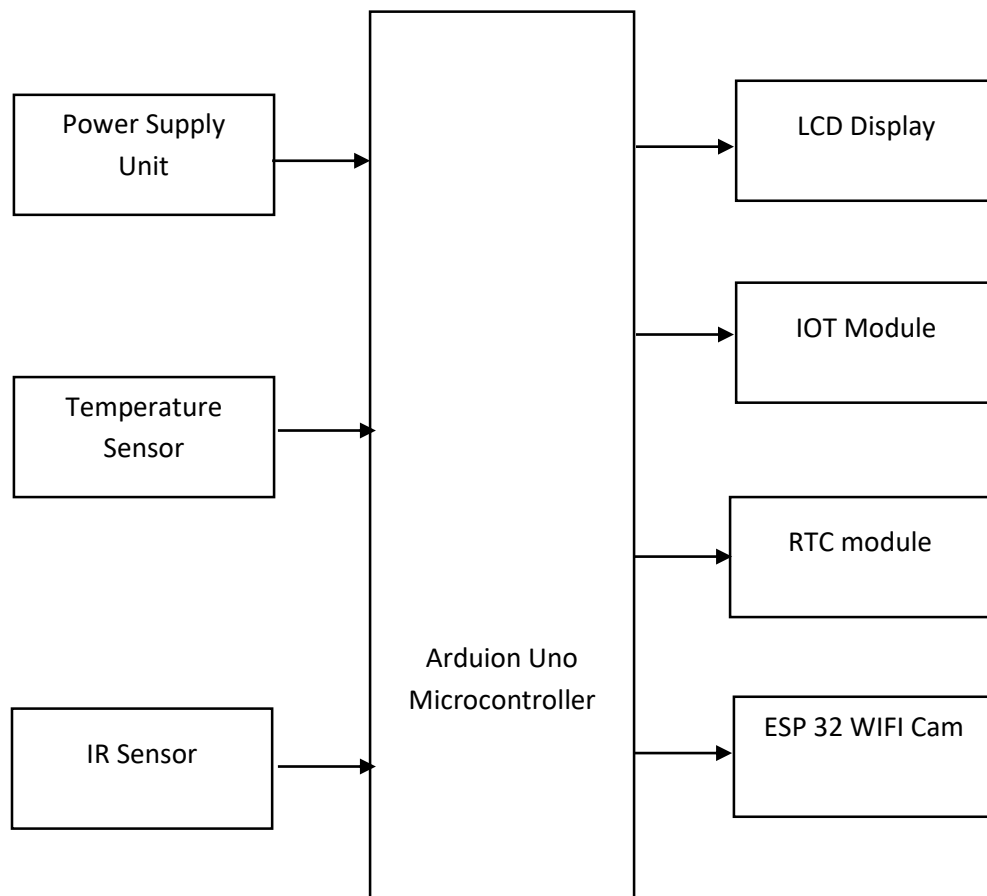

WORKING PRINCIPAL

Our system uses IR sensor, temperature as well as humidity sensing of trucks trailer to keep track of vegetables and fruits in their appropriate quality. The sensors are connected to a microcontroller to track the status which is in turn interfaced to an LCD display as well as it share the data through IOT with the help of internet in order to transmit alerts. And also If system detects any abrupt changes in trucks humidity or external temperature, the system automatically alerts the user about the trailers' and also it will turn on the ESP 32 cam for monitoring LIVE video streaming status over IOT and also shows details of humidity and temperature level of environment inside the truck live over the internet. Thus IOT based food quality tracking system effectively uses internet to monitor the environment and start the heater or fogger to increase or decrease the temperature or humidity inside the trucks, to maintain the quality of food to be transport.

HARDWARE DESCRIPTION**POWER SUPPLY**

The ac voltage, typically 220V rms, is connected to a transformer, which steps that ac voltage down to the level of the desired dc output. A diode rectifier then provides a full-wave rectified voltage that is initially filtered by a simple capacitor filter to produce a dc voltage. This resulting dc voltage usually has some ripple or ac voltage variation.

A regulator circuit removes the ripples and also remains the same dc value even if the input dc voltage varies, or the load connected to the output dc voltage changes. This voltage regulation is usually obtained using one of the popular voltage regulator IC units.

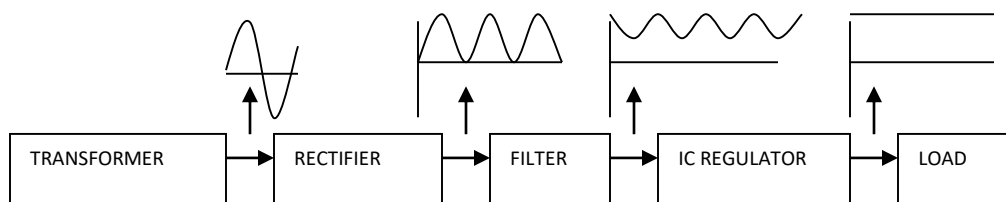

Fig. Block Diagram of Power supply

Working principle

Transformer

The potential transformer will step down the power supply voltage (0-230V) to (0-6V) level. Then the secondary of the potential transformer will be connected to the precision rectifier, which is constructed with the help of op-amp. The advantages of using precision rectifier are it will give peak voltage output as DC, rest of the circuits will give only RMS output.

Bridge rectifier

When four diodes are connected as shown in figure, the circuit is called as bridge rectifier. The input to the circuit is applied to the diagonally opposite corners of the network, and the output is taken from the remaining two corners. Let us assume that the transformer is working properly and there is a positive potential, at point A and a negative potential at point B. the positive potential at point A will forward bias D3 and reverse bias D4. The negative potential at point B will forward bias D1 and reverse D2. At this time D3 and D1 are forward biased and will allow current flow to pass through them; D4 and D2 are reverse biased and will block current flow. The path for current flow is from point B through D1, up through RL, through D3, through the secondary of the transformer back to point B. this path is indicated by the solid arrows. Waveforms (1) and (2) can be observed across D1 and D3.

One-half cycle later the polarity across the secondary of the transformer reverse, forward biasing D2 and D4 and reverse biasing D1 and D3. Current flow will now be from point A through D4, up through RL, through D2, through the secondary of T1, and back to point A. This path is indicated by the broken arrows. Waveforms (3) and (4) can be observed across D2 and D4. The current flow through RL is always in the same direction. In flowing through RL this current develops a voltage corresponding to that shown waveform (5). Since current flows through the load (RL) during both half cycles of the applied voltage, this bridge rectifier is a full-wave rectifier.

One advantage of a bridge rectifier over a conventional full-wave rectifier is that with a given transformer the bridge rectifier produces a voltage output that is nearly twice that of the conventional full-wave circuit.

This may be shown by assigning values to some of the components shown in views A and B. assume that the same transformer is used in both circuits. The peak voltage developed between points X and y is 1000 volts in both circuits. In the conventional full-wave circuit shown—in view A, the peak voltage from the center tap to either X or Y is 500 volts. Since only one diode can conduct at any instant, the maximum voltage that can be rectified at any instant is 500 volts.

The maximum voltage that appears across the load resistor is nearly-but never exceeds-500 volts, as result of the small voltage drop across the diode. In the bridge rectifier shown in view B, the maximum voltage that can be rectified is the full secondary voltage, which is 1000 volts. Therefore, the peak output voltage across the load resistor is nearly 1000 volts. With both circuits using the same transformer, the bridge rectifier circuit produces a higher output voltage than the conventional full-wave rectifier circuit.

IC voltage regulators

Voltage regulators comprise a class of widely used ICs. Regulator IC units contain the circuitry for reference source, comparator amplifier, control device, and overload protection all in a single IC. IC units provide regulation of either a fixed positive voltage, a fixed negative voltage, or an adjustably set voltage. The regulators can be selected for operation with load currents from hundreds of milli amperes to tens of amperes, corresponding to power ratings from milli watts to tens of watts.

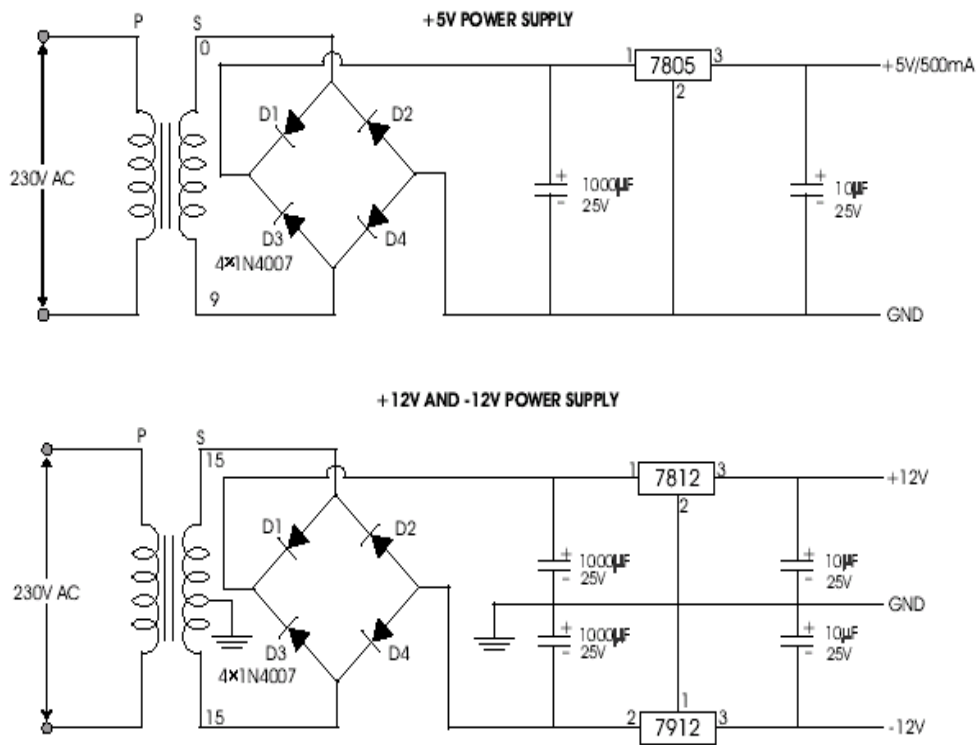

Fig.Circuit Diagram of Power Supply

A fixed three-terminal voltage regulator has an unregulated dc input voltage, V_i , applied to one input terminal, a regulated dc output voltage, V_o , from a second terminal, with the third terminal connected to ground. The series 78 regulators provide fixed positive regulated voltages from 5 to 24 volts. Similarly, the series 79 regulators provide fixed negative regulated voltages from 5 to 24 volts.

For ICs, microcontroller, LCD ----- 12 volts

For alarm circuit, op-amp, relay circuits ----- 5 volts

IR Sensor:

An infrared sensor is an electronic device that emits in order to sense some aspects of the surroundings. An IR sensor can measure the heat of an object as well as detects the motion. These types of sensors measures only infrared radiation, rather than emitting it that is called as a passive IR sensor. Usually in the infrared spectrum, all the objects radiate some form of thermal radiations. These types of radiations are invisible to our eyes that can be detected by

an infrared sensor. The emitter is simply an IR LED (Light Emitting Diode) and the detector is simply an IR photodiode which is sensitive to IR light of the same wavelength as that emitted by the IR LED. When IR light falls on the photodiode, the resistances and these output voltages, change in proportion to the magnitude of the IR light received.

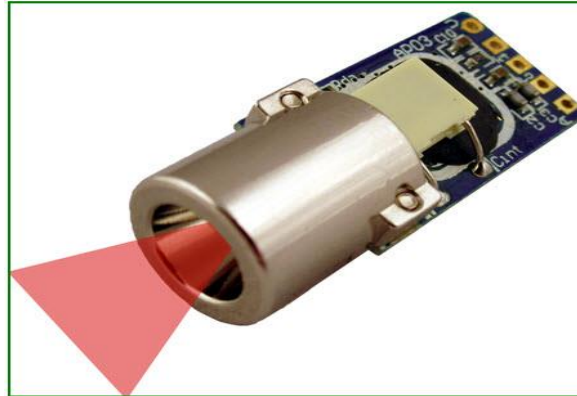

IR SENSOR

IR Sensor Circuit Diagram and Working Principle

An infrared sensor circuit is one of the basic and popular sensor module in an electronic device. This sensor is analogous to human's visionary senses, which can be used to detect obstacles and it is one of the common applications in real time. This circuit comprises of the following components

LM358 IC 2 IR transmitter and receiver pair

Resistors of the range of kilo ohms.

Variable resistors. LED

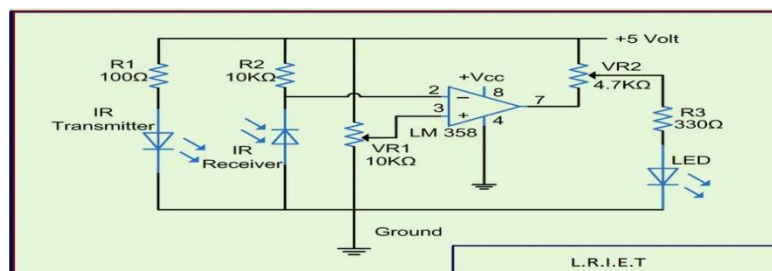

IR Sensor Circuit

In this project, the transmitter section includes an IR sensor, which transmits continuous IR rays to be received by an IR receiver module. An IR output terminal of the receiver varies depending upon its receiving of IR rays. Since this variation cannot be analyzed as such, therefore this output can be fed to a comparator circuit. Here an operational amplifier (op-amp) of LM 339 is used as comparator circuit. When the IR receiver does not receive a signal, the potential at the inverting input goes higher than that non-inverting input of the comparator IC (LM339). Thus the output of the comparator goes low, but the LED does not glow. When the IR receiver module receives signal to the potential at the inverting input goes low. Thus the output of the comparator (LM 339) goes high and the LED starts glowing. Resistor R1 (100 Ω), R2 (10k Ω) and R3 (330 Ω) are used to ensure that minimum 10 mA current passes through the IR LED Devices like Photodiode and normal LEDs respectively. Resistor VR2 (preset=5k Ω) is used to adjust the output terminals. Resistor VR1 (preset=10k Ω) is used to set the sensitivity of the circuit Diagram.

TEMPERATURE SENSOR (DHT11)

The DHT11 humidity and temperature sensor makes it really easy to add humidity and temperature data to your DIY electronics projects. It's perfect for remote weather stations, home environmental control systems, and farm or garden monitoring systems.

I'll first go into a little background about humidity, then I'll explain how the DHT11 measures humidity. After that, I'll show you how to connect the DHT11 to an Arduino and give you some example code so you can use the DHT11 in your own projects.

The DHT11 measures relative humidity. Relative humidity is the amount of water vapor in air vs. the saturation point of water vapor in air. At the saturation point, water vapor starts to condense and accumulate on surfaces forming dew. The saturation point changes with air temperature. Cold air can hold less water vapor before it becomes saturated, and hot air can hold more water vapor before it becomes saturated. Relative humidity is expressed as a percentage. At 100% RH, condensation occurs, and at 0% RH, the air is completely dry. The DHT11 detects water vapor by measuring the electrical resistance between two electrodes. The humidity sensing component is a moisture holding substrate with electrodes applied to the surface. When water vapor is absorbed by the substrate, ions are released by the substrate which increases the conductivity between the electrodes. The change in resistance between the two electrodes is proportional to the relative humidity. Higher relative humidity decreases the resistance between the electrodes, while lower relative humidity increases the resistance

between the electrodes. The DHT11 measures temperature with a surface mounted NTC temperature sensor (thermistor) built into the unit.

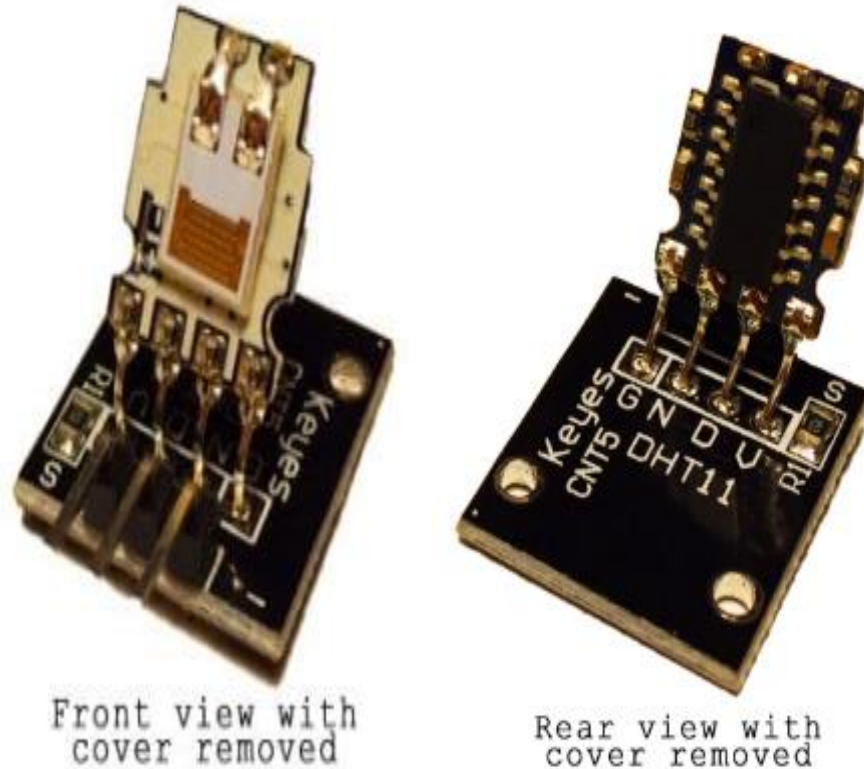

An IC mounted on the back of the unit converts the resistance measurement to relative humidity. It also stores the calibration coefficients, and controls the data signal transmission between the DHT11 and the Arduino: The DHT11 uses just one signal wire to transmit data to the Arduino. Power comes from separate 5V and ground wires. A 10K Ohm pull-up resistor is needed between the signal line and 5V line to make sure the signal level stays high by default (see the datasheet for more info). There are two different versions of the DHT11 you might come across. One type has four pins, and the other type has three pins and is mounted to a small PCB. The PCB mounted version is nice because it includes a surface mounted 10K Ohm pull up resistor for the signal line. Here are the pin outs for both versions:

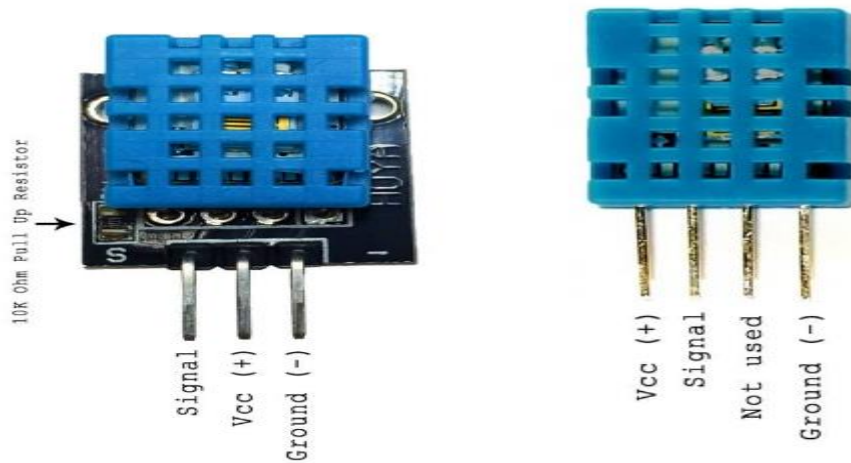

ARDUINO UNO CONTROLLER

The Arduino Uno is a microcontroller board based on the ATmega328. It has 14 digital input/output pins (of which six can be used as PWM outputs), six analog inputs, a 16 MHz crystal oscillator, a USB connection, a power jack, an ICSP header, and a reset button. It contains everything needed to support the microcontroller; simply connect it to a computer with a USB cable or power it with an AC-to-DC adapter or battery to get started. The Arduino Uno differs from all preceding boards because it does not use the FTDI USB-to-serial driver chip. Instead, it features the ATmega8U2 programmed as a USB-to-serial converter. Revision 2 of the Arduino Uno board has a resistor pulling the 8U2 HWB line to ground, making it easier to put into DFU mode. "Uno" means one in Italian and was chosen to mark the release of Arduino Software (IDE) 1.0. The Uno board and version 1.0 of Arduino Software (IDE) were the reference versions of Arduino, now evolved to newer releases. The Uno board is the first in a series of USB Arduino boards, and the reference model for the Arduino platform; for an extensive list of current, past or outdated boards see the Arduino index of boards. This is the Arduino Uno R3. In addition to all the features of the previous board, the Uno now uses an ATmega16U2 instead of the 8U2 found on the Uno (or the FTDI found on previous generations). This allows for faster transfer rates and more memory. No drivers needed for Linux or Mac (inf file for Windows is needed and included in the Arduino IDE), and the ability to have the Uno show up as a keyboard, mouse, joystick, etc. The Uno R3 also adds SDA and SCL pins next to the AREF. In addition, there are two new pins placed near the RESET pin. One is the IOREF that allow the shields to adapt to the voltage provided from the board. The other is a not connected and is reserved for future purposes. The Uno R3 works with all existing shields but can adapt to new shields which use these additional pins. The Arduino Uno is a microcontroller board based on the ATmega328. Arduino is an open-source, prototyping platform and its simplicity makes it ideal for hobbyists to use as well as professionals. The Arduino Uno has 14 digital input/output pins (of which 6 can be used as PWM outputs), 6 analog inputs, a 16 MHz crystal oscillator, a

USB connection, a power jack, an ICSP header, and a reset button. It contains everything needed to support the microcontroller; simply connect it to a computer with a USB cable or power it with a AC-to-DC adapter or battery to get started.

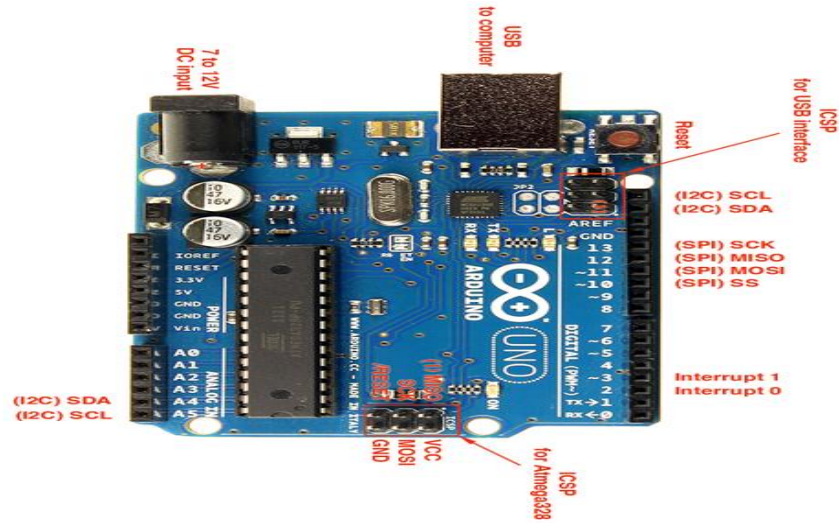

The Arduino Uno differs from all preceding boards in that it does not use the FTDI USB-to-serial driver chip. Instead, it features the Atmega8U2 microcontroller chip programmed as a USB-to-serial converter. "Uno" means one in Italian and is named to mark the upcoming release of Arduino 1.0. The Arduino Uno and version 1.0 will be the reference versions of Arduino, moving forward. The Uno is the latest in a series of USB Arduino boards, and the reference model for the Arduino platform.

BUZZER MODULE

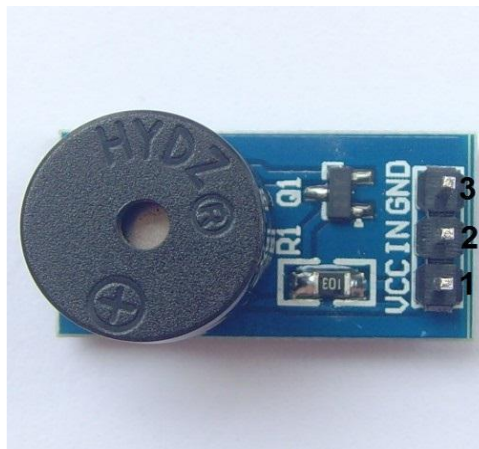

A buzzer or beeper is an audio signalling device, which may be mechanical, electromechanical, or piezoelectric. Typical uses of buzzers and beepers include alarm devices, timers and confirmation of user input such as a mouse click or keystroke. Buzzer is an integrated structure of electronic transducers, DC power supply, widely used in computers, printers, copiers, alarms, electronic toys, automotive electronic equipment, telephones, timers and other electronic

products for sound devices. Active buzzer 5V Rated power can be directly connected to a continuous sound, this section dedicated sensor expansion module and the board in combination, can complete a simple circuit design, to "plug and play."

SCHEMATIC DIAGRAM:

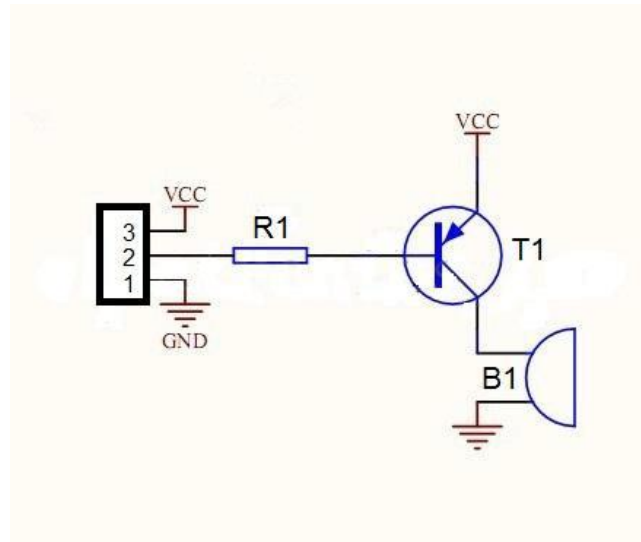

PIN CONFIGURATION

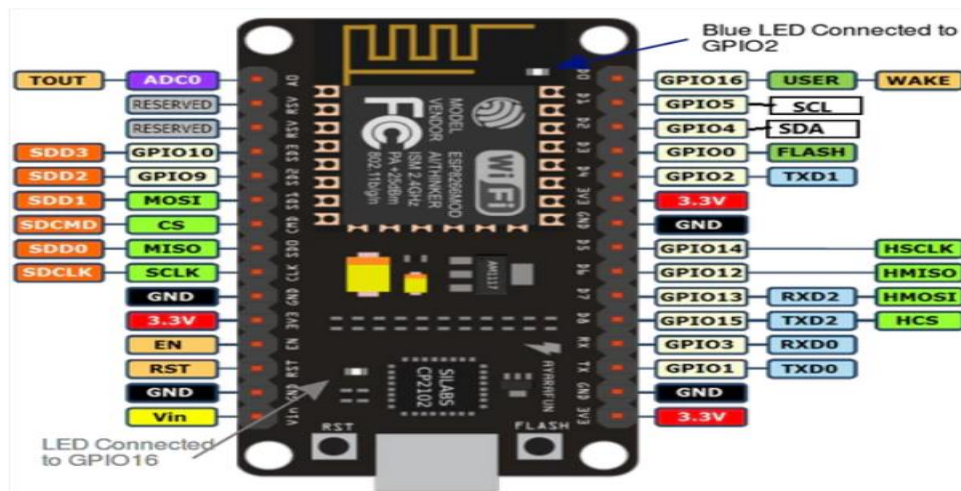

ESP32 Pins Types Descriptions

- Step 1 – Describe the Power Pins of ESP32.
- Step 2 – Describe the GPIO Pins of ESP32.
- Step 3 – Describe the Analog Pins of ESP32.
- Step 4 – Describe the I2C Pins of ESP32.
- Step 5 – Describe the DAC Pins of ESP32.
- Step 6 – Describe the Touch Pins of ESP32.

Step 7 – Describe the Transmitter and Receiver Pins of ESP32.

Pin Layout of ESP32

This is how an ESP32 wroom 30 pin microcontroller looks like. ESP32 Wroom 30 pin microcontroller has 30 pins with 15 pins on one side and 15 pins on the other side.

The Power Pins of ESP32

ESP32 has 2 GND output pins. It has two pins for positive voltages, Vin and 3V3. Vin can be connected to an external voltage source of 5V to 14V. 3V3 is the pin that can output 3.3 volts and powers the ESP32.

CONCLUSION

The proposed food monitoring system using IoT has a wide range of applications in food processing industry. This addresses the critical issues like food waste, food contamination etc. The threshold value of the device is maintained according to the food sample as each food has its own different threshold value. The array of gas sensors helps in reducing the chances of inaccurate readings. The device can be customized and can be used for different other applications. This project uses many low-cost sensors which will reduce the cost and improves the efficiency.

REFERENCE:

1. A Comprehensive Review on Accuracy in Ultrasonic Flow Measurement Using Advanced Methods, Kumar, P., et al., AIP Advances, Volume: 10, 2020 DOI: 10.1063/5.0022821
2. IoT Innovations in Sustainable Water and Wastewater Management and Water Quality Monitoring, Multiple Authors, IEEE Xplore,2023 DOI: 10.1109/JIOT.2023.10506924
3. IoT and ML-Based Water Flow Estimation Using Pressure Sensor, Multiple Authors, IEEE Conference Publication,2023 DOI: 10.1109/ICCE.2023.10440841
4. Smart Water Monitoring System for Real-Time Water Quality and Usage Monitoring, Multiple Authors, IEEE Conference Publication,2018 DOI: 10.1109/ICCE.2018.8597179
5. Demonstration of Real-Time Monitoring in Smart Graded-Water Supply Grid: An Institutional Case Study, Fabbiano, L., Baanu, J., Babu, P., Journal of Water Supply: Research and Technology—AQUA, 2020 DOI: 10.2166/aqua.2020.002
6. Smart Water Grids and Digital Twin for the Management of System Efficiency in Water Distribution Networks Multiple Authors, Water, Volume: 15(6), 2023 DOI: 10.3390/w15061129
7. Making Urban Water Smart: The SMART-WATER Solution, Saraswathi, T., Chowdury, A., Kusuma, A., Water Science & Technology, 2018 DOI: 10.2166/wst.2018.002

8. An Internet of Things-Based Smart Water Meter with Machine Learning for Water Quality Assessment, Multiple Authors, IEEE Xplore, 2020 DOI: 10.1109/ICCE.2020.10440841
9. Autonomous Data-Driven Water Management Using IoT and Machine Learning, Multiple Authors, IEEE Xplore, 2022 DOI: 10.1109/ICCE.2022.10440841
10. Machine Learning for Water Demand Forecasting: Case Study in a Brazilian Coastal City Various Authors, Water Practice & Technology, 2023
11. Self-Organizing Map-Based Anomaly Detection in Water Networks, Clark, P., Mehta, R., Industrial Engineering and Operations Management Conference Proceedings, 2021
12. Real-Time Data Analysis Platform for Short-Term Water Consumption Forecasting with Machine Learning, Boudhaouia, A., Wira, P., Forecasting, Volume: 3, 2021 DOI: 10.3390/forecast3040042
13. A Real-Time IoT Framework for Water Management Using Smart Meters, Ahmed, S., et al., Journal of Cleaner Production, 2022
14. IoT and Cloud Computing-Based Smart Water Metering System, Multiple Authors, IEEE Xplore, 2020 DOI: 10.1109/ICCE.2020.8597179
15. Advanced Leak Detection Using Ultrasonic Flow Meters, Drenthen, J.G., et al., Journal of Fluids Engineering (ASME), 2021.
16. Booma, J., Anitha, P., Amosedinakaran, S., & Bhuvanesh, A. (2025). Real-time electricity capacity expansion planning using chaotic ant lion optimization by minimizing carbon emission. Journal of the Chinese Institute of Engineers, 1–15. <https://doi.org/10.1080/02533839.2025.2464575>.
17. Booma Jayapalan, Sathishkumar, R., Prakash, I.A., Venkateswaran, M. "Optimizing wind energy efficiency in IoT-driven smart power systems using modified fuzzy logic control" AI Approaches to Smart and Sustainable Power Systems, 2024, pp. 250–273.
18. Booma Jayapalan, Mahadevan Krishnan, Karunanithi Kandasamy & Kannan Subramanian, 2018, "Integrated Strategies for load demand management in the State of Tamil Nadu", Journal of Electrical Engineering, vol. 18, edition 4, ISSN: 1582-4594, pp.151-160.
19. Booma Jayapalan, Mahadevan Krishnan, Karunanithi Kandasamy & Kannan Subramanian, 2017, "Renewable energy penetration and its impact on Reliability: A case study of Tamil Nadu", Journal of Computational and Theoretical Nano science, vol. 14, no. 8, pp. 4036-4044, DOI: 10.1166/jctn.2017.6752.
20. Arshi Siddiqui, Khan Chand and N.C.Shahi(2021). Effect of process parameters on extraction of pectin from sweet lime peels. Journal of The Institution of Engineers (India): Series A, 102(2 June):469-478
21. Ramya, C. (2019). Claude McKay and Black Diaspora. Strength for Today and Bright Hope for Tomorrow Volume 19: 6 June 2019 ISSN 1930-2940, 289.
22. Anand Kumar, Khan Chand, Navin C Shahi, anil Kumar and A K Verma (2017) Optimization of coating material on jaggery for augmentation of storage quality. Indian Journal of Agricultural Sciences, 87 (10): 1391-1397.

23. Ramya, C. (2019). Ernest Hemingway's Portrayal of Female Characters. *Strength for Today and Bright Hope for Tomorrow* Volume 19: 5 May 2019 ISSN 1930-2940, 268.
24. Khan Chand and R.K. Pandey. (2012). Optimization of Foam Mat Drying Process Variables for Malta Powder. *International Journal of Food, Agriculture and Veterinary Sciences*, 2(2):67-73.
25. Ramya, C. (2020). Paule Marshall and Feminine Aesthetic. *Language in India*, 20(10).
26. Anjali Sharma and Khan Chand(2015).Optimization of Fermentation Parameters to Reduce Fermentation Time of Idli Batter Using RSM. *Int. Journal of Science and Research*, 4(1, Jan):2254-2258
27. Ramya, C. (2020). Saru in Shashi Deshpande's *The Dark Holds No Terrors*. *Language in India*, 20(7).
28. Khan Chand, Sanjay Kumar and S. B.Bhardwaj (2016). Vacuum drying of concentrated malta juice for production of malta powder using RSM. *International Journal of Agriculture, Environment and Biotechnology*, 9(1Feb.):715-725
29. Anjali Sharma and Khan Chand(2016).Optimization of fermenting parameters for Idli batter. *European Journal of Biotechnology and Bioscience*,vol.4 (2,Feb):48-52
30. Ramya, C. (2020). Somerset Maugham: Mirroring Human Life and Human Weaknesses. *Language in India*, 20(3).
31. Khan Chand and Anupama Singh (2017). Effect of Process Parameters on Quality of Dried Nettle Leaves. *International Journal of Chemical Studies*, 5(5 Sept):255-259.
32. Ramya, C. (2020). Rhetoric and Poetic Excellence of Philip Larkin. *Strength for Today and Bright Hope for Tomorrow* Volume 20: 5 May 2020 ISSN 1930-2940, 1.
33. Sachin Surwade and Khan Chand (2017). Antimicrobial Packaging of Food: An Overview. *European Journal of Biotechnology and Bioscience*, 5(5 Sept):85-90.
34. Ramya, C. (2018). Anita Desai as an Existentialist Exploring the Emotional Turbulence and Chaotic Inner World. *Language in India*, 18(9), 197-202.
35. Ramya, C. (2020). Tagore's Concept of Womanhood and His Deep Insight into the Heart of a Woman as Pictured in His Short Stories. *Strength for Today and Bright Hope for Tomorrow* Volume 20: 8 August 2020 ISSN 1930-2940, 235.

36. Khan Chand, Shusheel Kumar and N. C. Shahi (2018). Effect of active packaging and coating materials on quality parameters of jaggery cubes. *International Journal of Engineering Research and Technology*, 7(1January):4-9.
37. Ramya, C. (2020). A House for Mr. Biswas VS Naipaul's Journey from Self-discovery to Search for Identity and Stability. *Strength for Today and Bright Hope for Tomorrow* Volume 20: 6 June 2020 ISSN 1930-2940, 68.
38. Ramya, C. (2020). Rhetoric and Poetic Excellence of Philip Larkin. *Strength for Today and Bright Hope for Tomorrow* Volume 20: 5 May 2020 ISSN 1930-2940, 1.
39. NR, D., GK, D. S., & Kumar Pareek, D. P. (2022, February). A Framework for Food recognition and predicting its Nutritional value through Convolution neural network. In *Proceedings of the International Conference on Innovative Computing & Communication (ICICC)*.
40. Ara, T., Ambareen, J., Venkatesan, S., Geetha, M., & Bhuvanesh, A. (2024). An energy efficient selection of cluster head and disease prediction in IoT based smart agriculture using a hybrid artificial neural network model. *Measurement: Sensors*, 32, 101074.
41. Divyashree, H. S., Avinash, N., Manjunatha, B. N., Vishesh, J., & Mamatha, M. (2024). Enhancing secrecy using hybrid elliptic curve cryptography and Diffie Hellman key exchange approach and Young's double slit experiment optimizer based optimized cross layer in multihop wireless network. *Measurement: Sensors*, 31, 100967.
42. Sidharth, S. (2019). *Enhancing Security of Cloud-Native Microservices with Service Mesh Technologies*.
43. Sidharth, S. (2021). *Multi-Cloud Environments: Reducing Security Risks in Distributed Architectures*
44. Sidharth, S. (2020). *The Rising Threat of Deepfakes: Security and Privacy Implications* 17. Sidharth, S. (2022). *Zero Trust Architecture: A Key Component of Modern Cybersecurity Frameworks*.
45. Sidharth, S. (2024). *Strengthening Cloud Security with AI-Based Intrusion Detection Systems*
46. Nila, M., Vijayalakshmi, A., Balamurugan, M., Gayathri, S., Thangapandi, K., Punniyamoorthy, K., & Prabakaran, N. (2024). *Orthogonal Stability of Additive*

- Functional Equation in Fuzzy β -Normed Spaces. *International Journal of Analysis and Applications*, 22, 231-231.
47. Balamurugan, M., Hakami, K. H., Ansari, M. A., & Loganathan, K. (2024). An Innovative Perspective on Bipolar Fuzzy Fantastic Ideals in BCK/BCI-Algebras. *European Journal of Pure and Applied Mathematics*, 17(4), 3973-3983. 22.
48. Sidharth, S. (2023). AI-Driven Anomaly Detection for Advanced Threat Detection.
49. Sidharth, S. (2023). Homomorphic Encryption: Enabling Secure Cloud Data Processing.
50. Al-Qaysi, Z. T., Suzani, M. S., bin Abdul Rashid, N., Aljanabi, R. A., Ismail, R. D., Ahmed, M. A., ... & Kumar, H. (2024). Optimal time window selection in the Wavelet Signal Domain for brain-computer interfaces in Wheelchair Steering Control. *Applied Data Science and Analysis*, 2024, 69-81.
51. Sharma, C. M., & Kumar, H. (2014, March). Architectural framework for implementing visual surveillance as a service. In *2014 International Conference on Computing for Sustainable Global Development (INDIACom)* (pp. 296-301). IEEE.
52. Ahmad, Z., AlWadi, B. M., Kumar, H., Ng, B. K., & Nguyen, D. N. (2024). Digital transformation of family-owned small businesses: a nexus of internet entrepreneurial self-efficacy, artificial intelligence usage and strategic agility. *Kybernetes*.
53. Sidharth, S. (2019). Quantum-Enhanced Encryption Methods for Securing Cloud Data.
54. Sidharth, S. (2022). Enhancing Generative AI Models for Secure and Private Data Synthesis.
55. Deepa, R., Karthick, R., Velusamy, J., & Senthilkumar, R. (2025). Performance analysis of multiple-input multiple-output orthogonal frequency division multiplexing system using arithmetic optimization algorithm. *Computer Standards & Interfaces*, 92, 103934.
56. Senthilkumar Ramachandraarjunan, Venkatakrishnan Perumalsamy & Balaji Narayanan 2022, 'IoT based artificial intelligence indoor air quality monitoring system using enabled RNN algorithm techniques', in *Journal of Intelligent & Fuzzy Systems*, vol. 43, no. 3, pp. 2853-2868

57. Senthilkumar,Dr.P.Venkatakrishnan,Dr.N.Balaji, Intelligent based novel embedded system based IoT Enabled air pollution monitoring system, ELSEVIER Microprocessors and Microsystems Vol.77, June 2020